



# Wrangler® 2016

## 20-Inch Automatic Scrubber



A tight turning radius and scrub head lock-down feature allow the mid-sized Wrangler 2016 to tackle heavy scrub and standard scrub jobs with ease. Its 20-in. scrubbing path makes quick work of any task. A rugged, rotocast-polyethylene body and 7-gauge steel frame deliver long term durability.

- Large tanks—16-gallon (61 l.) solution and 17-gallon (64 l.) recovery—keep this mid-size scrubber on the job longer.
- Battery-powered models include an on-board battery charger for convenient recharging anywhere an electric outlet is available.
- Swing squeegee with breakaway feature and Linatex blades provides excellent pickup even on turns, both forward and reverse.
- Front-fill and drain of tanks saves time. Both functions can be completed by simply taking the machine to a slop sink, without turning it around.
- Three models of the Wrangler 2016 are available to fit your needs. The Wrangler 2016 DB is battery-powered with wheel drive for easier maneuvering, especially up inclines. Two pad-assist models are also available—the battery-powered 2016 AB and cord-electric 2016 AE.

**NSS® Enterprises, Inc.**  
3115 Frenchmens Road  
Toledo, Ohio 43607-2958  
USA  
[www.nss.com](http://www.nss.com)



Printed on Green Seal® certified paper that contains 30% recycled post-consumer fiber.

## Big Scrubber Features In A Mid-Sized Machine

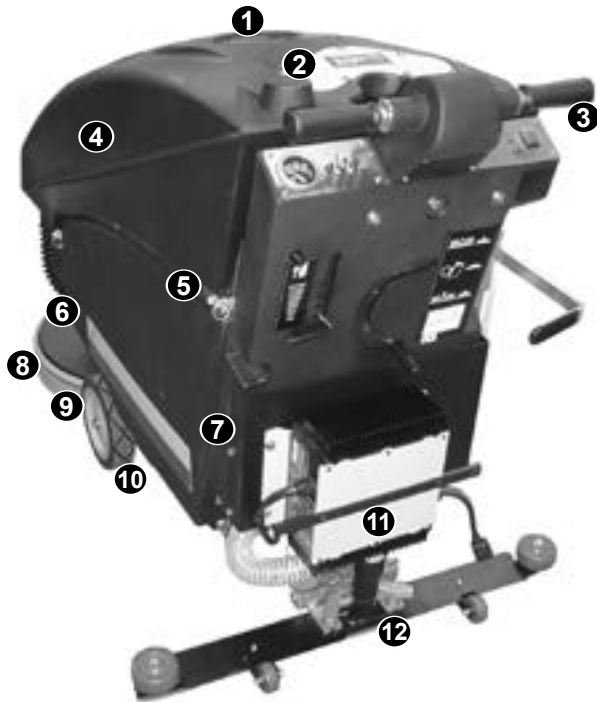

All Wrangler 2016 models are available with a curved squeegee assembly. Ideal for industrial applications, the curved squeegee funnels water and debris into the center, traps it and vacuums it in one pass.

- 1 The solution-fill port is on the outside of the Wrangler 2016—no need to open up the machine to add solution.
- 2 The percolator helps break down recovered foam to protect the vacuum motor.
- 3 The wheel-drive unit features twist-grip handle to easily control propulsion.
- 4 The polyethylene body is non-corrosive and will withstand heavy-duty commercial use. The 17-gallon (53 L) recovery tank minimizes emptying for added productivity.
- 5 The side opening provides easy access to the Wrangler 2016 batteries.
- 6 A powerful 0.75 HP gear motor rotates the scrub brush at a steady 270 RPM.
- 7 The built-in battery tray drain permits quick clean-up in the case of battery acid spills inside the battery compartment.
- 8 The scrub head tilts up for easy pad and brush changes, and is offset for close edge cleaning.
- 9 A solenoid automatically shuts off the solution flow when the brushes stop, preventing accidental flooding during pauses in operation.
- 10 Mid-mounted wheels provide superior maneuverability and a tight turning radius.
- 11 The on-board battery charger allows the machine to be charged anywhere an electrical outlet is available.
- 12 The 32-inch (81 cm) wide Linatex squeegee picks up in forward and reverse.



## Attachments For Cleaning Hard-To-Reach Areas

All Wrangler 2016 models include a wet pick-up kit (#2392129), which includes a 2-piece steel wand, 7-ft vacuum hose, 15-in squeegee tool with wheels, and 5-in aluminum connector. Connect the hose to your Wrangler 2016, and you are ready to vacuum those hard-to-reach areas, like corners, where no automatic scrubber can go. When not in use, the tube handle can be stored on top of the machine for easy access.

## Keen Attention To Squeegees



The unique breakaway squeegee assembly on the Wrangler 2016 keeps the machine working when others must be taken off the job to be repaired. If the assembly is inadvertently caught on a fixture or doorway, it releases from the holding bracket at the rear of the machine without bending or breaking. The assembly can be easily re-installed by simply hand tightening two control knobs.

The Linatex squeegee blades for the Wrangler 2016 assure quality control and proper water pickup, which is important for protection against slip-and-fall accidents on wet floors.

## Custom Battery Configurations



Choose from two different battery systems to meet your needs:

- Four 6V, 235 AH batteries provide up to 3.5 hours of run time.
- Two 12V, 130 AH batteries provide up to 1.5 hours of run time.

## Control Option



The Wrangler 2016 is available with a Key-And-Hour-Meter option. The key increases safety, preventing unauthorized operation. The Hour Meter makes it easy to track runtimes for routine maintenance procedures.

# Battery-Powered Wrangler 2016 DB (Wheel-Drive) and Wrangler 2016 AB (Pad-Assist) Specifications

<b>Brush/Pad</b>	20 in (51 cm)
<b>Pad Drive Motor</b>	
Type	Permanent magnet gear motor
Voltage	24V
HP	0.75 HP
Speed	200 RPM
Pressure	Floating 60 lbs (27 kg) Locked 80 lbs (36 kg)
<b>Vacuum Motor</b>	
Type	3-stage, bypass tangential discharge
Voltage	24V
HP	0.75 HP
Waterlift	58 in (147 cm)
<b>Batteries (Runtime)</b>	2016 AB, Two 12V 130 AH (1.5 hours) 2016 AB, Four 6V 235 AH (3.5 hours) 2016 DB, Two 12V 130 AH (1.2 hours) 2016 DB, Four 6V 235 AH (3.0 hours)
<b>Drive Motor</b>	
	2016 DB model only
Type	Gear-reduced transaxle w/ permanent magnet motor
Voltage	24V
HP	0.34 HP
<b>Construction</b>	
Solution Tank	Rotocast Polyethylene 16 gallons (61 L)
Recovery Tank	Rotocast Polyethylene 17 gallons (64 L)
Frame	7-gauge steel
Wheels	Two 8 in (20 cm) x 4 in (10 cm) dia with slip grip tread
Casters	Delron; two 3.5 in (9 cm) dia x 1.25 in (3 cm) ball bearing swivel casters
Float	Ball type
<b>Squeegee</b>	32-in (81 cm) straight swing-type with breakaway feature; picks up in forward and reverse. Optional 35-in (89 cm) curved squeegee available
<b>Tool Kit</b>	2-piece wand with 7-ft (2 m) hose, hose connector and 17 in (43 cm) squeegee tool
<b>Sound Level</b>	65 dBA @ operator
<b>Dimensions</b>	
Length	55 in (140 cm)
Width	21 in (53 cm)
Height	39.5 in (100 cm)



<b>Weight</b>	
Machine DB 235 AH	483 lbs (219 kg)
Machine AB 235 AH	433 lbs (197 kg)
Machine AB 130 AH	315 lbs (143 kg)
Shipping DB 235 AH	558 lbs (253 kg)
Shipping AB 235 AH	508 lbs (231 kg)
Shipping AB 130 AH	380 lbs (173 kg)
<b>Shipping Class</b>	70

<b>Warranty</b>	3 year limited, 10 years poly parts
-----------------	-------------------------------------

<b>Productivity</b>	
Theoretical 2016 DB	20,000 sq ft per hour (1,858 m <sup>2</sup> )
Theoretical 2016 AB	14,960 sq ft per hour (1,390 m <sup>2</sup> )
Practical 2016 DB	9,274 sq ft per hour (862 m <sup>2</sup> )
Practical 2016 AB	6,960 sq ft per hour (647 m <sup>2</sup> )

## Cord-Electric Wrangler 2016 AE (Pad-Assist) Specifications (When different from battery models)

<b>Pad Drive Motor</b>	
Type	2-stage bypass tangential discharge
Voltage	115V (240V available)
HP	0.75 HP

<b>Vacuum Motor</b>	
Type	Permanent magnet, gear motor
Voltage	115V (240V available)
HP	0.75 HP
Waterlift	78 in (208 cm)
Power	75 ft (22.5 cm) 14-3 cord

<b>Weight</b>	
Machine	227 lbs (103 kg)
Shipping	290 lbs (132 kg)
<b>Shipping Class</b>	125



Twister approval means stone and concrete floors can be scrubbed without harmful chemicals, protecting the environment.

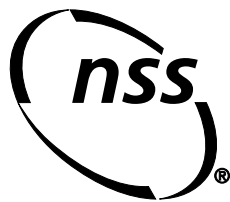

**NSS Enterprises, Inc.**  
 3115 Frenchmens Road  
 Toledo, OH 43607-2958  
 USA  
 P: (800) 677-1663  
 F: (419) 531-3761  
 mailus@nss.com  
 www.nss.com  
 Specifications subject to change without notice.

DISTRIBUTED BY