

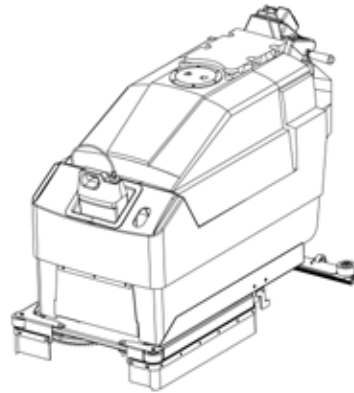

Sidekick

Chemical Metering System



Add a Sidekick Chemical Metering System to any Wrangler 2625, 2730, or 3330 for accurate on-board chemical dilution. The Sidekick can be factory installed or added later with a field-installation kit.

- Ten dilution ratios allow the use of a wide assortment of chemicals. (20:1, 32:1, 50:1, 64:1, 100:1, 128:1, 150:1, 200:1, 256:1, 300:1)
- Chemicals and clean water are never mixed in the solution tank, eliminating wasted, unused solution.
- Dilution control settings are conveniently located at the operator position.
- The Sidekick works with any brand of chemical. The bottle holder will accept any one gallon F-style bottle.
- Using the original chemical container preserves product safety warnings and improves compliance with OSHA hazard communication standards.

NSS Enterprises, Inc.
3115 Frenchmens Road
Toledo, Ohio 43607-2958
USA
www.nss.com



Printed on Green Seal® certified paper that contains 30% recycled post-consumer fiber.

Sidekick Specifications

Dilution Control

Settings 10 pre-sets (20:1, 32:1, 50:1, 64:1, 100:1, 128:1, 150:1, 200:1, 256:1, 300:1)

Chemical Storage

F-style one-gallon detergent bottle fits in holder near scrub head

Dimensions

Length 5.12 in (13 cm)
 Height 4.75 in (12 cm)
 Width 4.5 in (11.5 cm)
 Weight 2 lbs (1 kg)

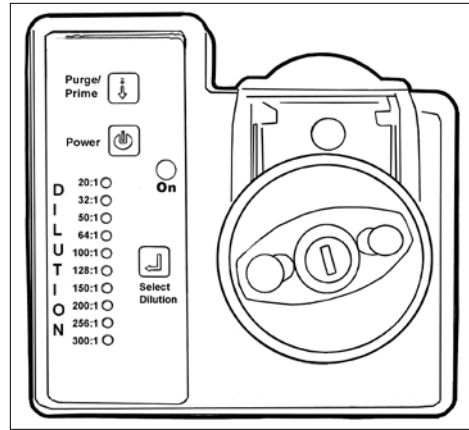

How it works

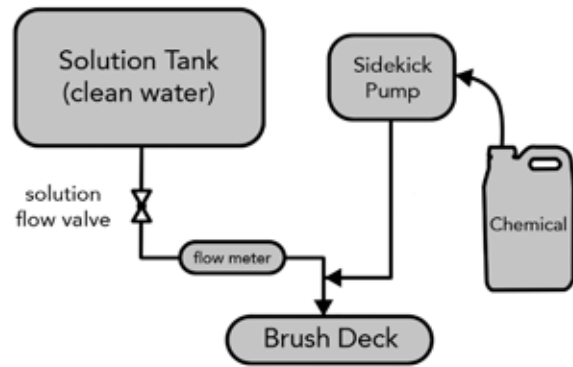

A flow meter in the solution line continuously measures the amount of water used. The Sidekick pump uses this information to send exactly the right amount of detergent to the scrub deck. If the operator changes the water flow, the Sidekick Chemical Metering System automatically adjusts the amount of chemical used.



DO NO HARM™

Inline chemical metering eliminates wasting detergents, keeping drains and watersheds free of large amounts of diluted chemicals.

Without the need to pre-mix chemical with solution, the Sidekick keeps operators away from concentrated detergents.

Because there is a precise chemical usage (using only what is necessary to clean the floor) the customer saves valuable resources.

DISTRIBUTED BY



NSS Enterprises, Inc.
 3115 Frenchmens Road
 Toledo, OH 43607-2958
 USA

P: (800) 677-1663
 F: (419) 531-3761

mailus@nss.com
 www.nss.com

Specifications subject to change without notice.